

# Tineco 6470641 Floor One S5 Pro Series Smart Cordless Vacuum and Washer Instruction Manual



[Home](#) » [Tineco](#) » Tineco 6470641 Floor One S5 Pro Series Smart Cordless Vacuum and Washer Instruction Manual

## Contents [ [hide](#) ]

- [1 Tineco 6470641 Floor One S5 Pro Series Smart Cordless Vacuum and Washer](#)
- [2 Precautionary measures:](#)
- [3 Important Safety Instructions](#)
- [4 Battery use and care](#)
- [5 Overview](#)
- [6 Accessories](#)
- [7 Assembly](#)
- [8 Operation](#)
- [9 Filling Clean Water Tank](#)
- [10 Digital Display](#)
- [11 Cleaning Mode Selection](#)
- [12 Maintenance](#)
- [13 Brush Roller Cover](#)
- [14 Specifications](#)
- [15 Troubleshooting](#)
- [16 Warranty](#)
- [17 Documents / Resources](#)
  - [17.1 References](#)
- [18 Related Posts](#)



**Tineco 6470641 Floor One S5 Pro Series Smart Cordless Vacuum and Washer**



### **Precautionary measures:**

1. Do not operate the hard floor washer too close to heaters, radiators or other hot surfaces.
2. Before inserting the charger into the wall, make sure your hands are dry.
3. Before turning on the hard floor washer, safely remove any large objects from the floor or cleaning surface in order to prevent damage to the filter.
4. When you want to remove the charger from the power socket, do not use the power cable, gently pull the plug from the power socket.

Do not use this hard floor washer if the housing and/or the charger housing is damaged.

### **Important Safety Instructions**

**IMPORTANT!** Always switch off the hard floor washer before cleaning, when not in use or attempting any maintenance task. The charger must only be connected to an AC power supply at the voltage shown on the rating label. This hard floor washer should only be used for its intended purpose as described in this instruction manual. Never operate the washer without filters.

When using your hard floor washer, basic precautions should always be observed, including the following;

1. This appliance is not intended for use by persons (including children) with reduced physical, sensory, mental capabilities or lack of experience and knowledge, unless they have been given supervision or instruction concerning use of the appliance by a person responsible for their safety.
2. Children should be supervised to ensure that they do not play with the appliance.
3. To prevent electrical shock, do not immerse the appliance, battery or power plug into water or other liquids.
4. To prevent electrical shock, do not use the hard floor washer outdoors.

5. Always check the power cord before use, the power cord and the power adapter should be in a good condition and must not be damaged. If the power cord or the charger adaptor is damaged or defective, it must be replaced.
6. The appliance and charger are intended for domestic indoors use only
7. Do not unplug the charger by pulling on the power cord. To unplug, grasp the power adapter, not the power cord and gently pull the power adapter from the power socket.
8. Do not handle or operate the appliance with wet hands. Follow electrical safety precautions at all times.
9. Do not attempt to change the attachments while the appliance is switched on. Use only manufacturer's recommended accessories.
10. Do not operate the hard floor washer too close to heaters, radiators and other hot surfaces.
11. Do not use the appliance to pick up flammable items or combustible liquids (i.e. gasoline, hot ashes, cigarettes, matches, explosive materials or anything burning) or use in areas where such substances and items may be present.
12. Do not use the appliance to pick up toxic materials (i.e. chlorine, bleach, ammonia).
13. Never operate or use the appliance without the filters in place.
14. Before using the hard floor washer, remove any large or sharp objects from the floor or cleaning surface in order to prevent damage to the filter.
15. If the air inlet or floor head is blocked, switch off the washer straight away.  
Clear the blocked object before attempting to start the hard floor washer again.
16. Before carrying out any maintenance or cleaning the filters, always switch off the hard floor washer.
17. Keep openings away from your face and body.
18. Do not use the hard floor washer if it is damaged or broken. If connection cables are damaged, have them replaced immediately.
19. Never clean the hard floor washer or any of the electrical parts, especially the electrical connections with water or liquid cleaners.
20. Never attempt to make any modifications to the hard floor washer and charger.
21. Always store the appliance and charger indoors in a cool and dry place.
22. Never run over the power cable with the power head, as this may cause damage to the power cable.
23. Keep your hands away from the roller brush while the hard floor washer is switched on.
24. To prevent unnecessary wear on the roller brush, keep it moving while in operation.
25. Damage caused by improper use or by not observing the instructions in this manual will void the warranty

## **Battery use and care**

1. The appliance is only to be used with the charger provided with the appliance.
2. Only charge the battery inside the washer or the charging dock. Only use the specifically designated charger to charge the product.
3. When the appliance is not in use, keep it away from other metal objects, like paper clips, coins, keys, nails, screws or other small metal objects that can make a connection from one terminal to another. Shorting the appliance terminals together may cause burns or a fire.
4. Under abusive conditions, liquid may be ejected from the battery; avoid contact. If contact occurs, flush with water immediately. If liquid comes into contact with your eyes, seek medical help immediately.
5. Do not charge or store the appliance outdoors or inside the car. Only charge or store the battery in a dry indoor area where the temperature is more than 4 deg C but less than 40 deg C. The charger is for indoor use only.

6. Never attempt to open the battery for any reason. If the plastic housing of the battery casing breaks or cracks, immediately discontinue use and do not recharge.
7. The charger is not a serviceable part.
8. Before disposal of your battery, fully discharge your battery by running the product until it stops.
9. The washer contains a Lithium battery. Do not dispose the appliance with your local garbage. Contact your local council for instructions on how to safely dispose of the battery.
10. Do not use the charger to charge a non-chargeable battery.
11. The Battery can only be replaced by a qualified technician. Do not try to open the cleaner to replace the battery. Failure to do so may cause risk of injury and fire.

## Overview

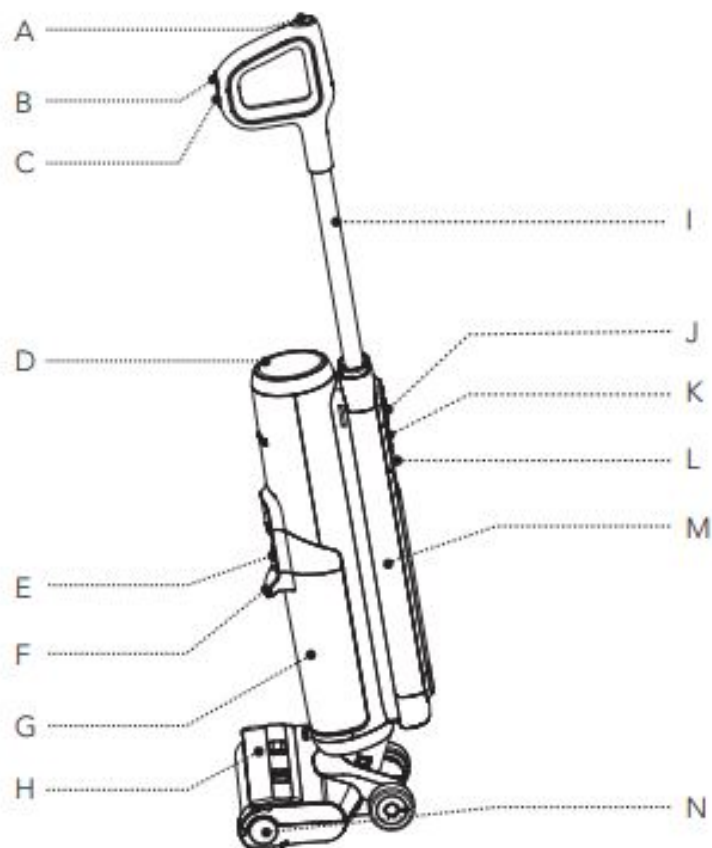



- A. Self-cleaning Button
- B. AUTO/MAX/SUCTION Mode
- C. Power On/Off
- D. Digital Display
- E. Dirty Water Tank Release
- F. Dirty Water Tank Handle
- G. Dirty Water Tank (DWT)
- H. Brush Roller Cover
- I. Tube
- J. WiFi/Mute Button
- K. Clean Water Tank Release
- L. Clean Water Tank Handle
- M. Clean Water Tank (CWT)
- N. Brush Roller
- O. Deodorizing & Cleaning Solution
- P. Cleaning Tool
- Q. Dry Filter & Holder
- R. Accessory Holder
- S. Adaptor
- T. Charging Base

## Accessories

### Note:

Accessories may vary between markets. If you would like to purchase accessories or consumables, please contact Customer Service on AUS: 1800 815 270, NZ: 0800 282 288

## Deodorizing & Cleaning Solution

Removes dirt, grime, grease and tough stains from most types of hard surfaces, like tile, marble, sealed hardwood floors, and more.

Always use Tineco solution in your appliance.

Add one bottle cap of solution to each full tank of clean water.

## Brush Roller

Soft roller head with bristles can be used to vacuum and wash at the same time. It can be easily cleaned with the self-cleaning function.

## Dry Filter

Dry filter and filter net can block large particles and debris, ensure the appliance's durability.

**\* Please install the dry filter before use, or it may lead to weak suction.**

## Cleaning Tool

A full brush to clean the DWT, brush chamber and opening. The tool also has a bristled end to remove dirt and mud on the roller and DWT

## Assembly

### How to Assemble/Disassemble

Note: For water tank and brush assembly, please refer to "Operation" and "Maintenance".

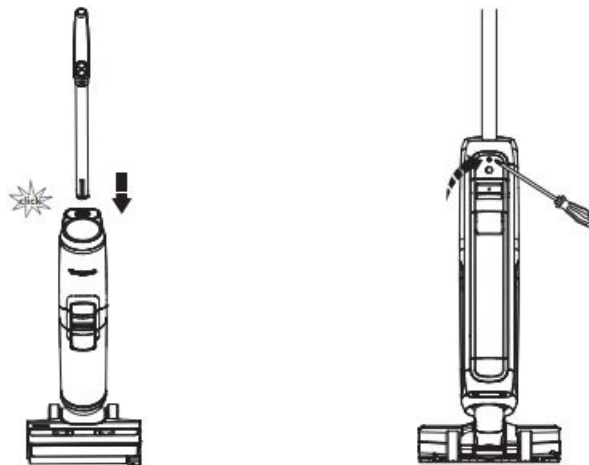

To assemble the handle, insert it into the appliance until you hear a click.

In the event that the product must be returned, please disassemble the handle. Press the spring to release the handle with a tool (like a screwdriver) and lift the released handle from the appliance.

## Operation

### Preparing for Use

Before first use, please charge the appliance for 4-5 hours (refer to "Charging Instructions" for details).

\* Based on results from Tineco lab tests. Lab temperature 39.2°F (4°C) ~ 104°F (40°C).

Press the button and the appliance will start in AUTO mode by default. Press it again to turn off the appliance. Switch between AUTO, MAX and SUCTION mode by pressing the button.

The appliance will stop working when put uprightly and start running again when you recline.

\* Do not recline more than 142° to protect against water leakage.

### Tips: (SUCTION mode not available)

- **Solution mode/ Water Only mode:**

Appliance starts with Solution mode by default. Power on while the appliance is upright, long-press for 3s to switch between the two modes.

- **Switch to Water Only mode:**

LED Loop: Red → Blue (use water only)

- **Switch to Solution mode:**

LED Loop: Blue → Red (use cleaning solution)

Place the appliance on the charging base vertically after use for recharge and storage.

**Note:**

- Selecting the appropriate mode depending on the CWT contents is vital for maximum dirt detection effectiveness.
- Do not vacuum foamed liquid.
- To vacuum water left on the surface, the appliance will switch off in 3 seconds after power off.

### Filling Clean Water Tank

Press the Clean Water Tank release button to remove it from the appliance

Place the tank back into the appliance. You should hear a “Click” if done correctly.

Open the tank cap, and fill with tap water to the Max line. When deep cleaning is necessary, add one bottle cap of solution to the CWT and tightly close the cap

**Note:** Only use water under 140°F/60°C. **DO NOT USE HOT WATER.**

### Charging Instructions

To charge the appliance, place the appliance on the charging base and plug the adaptor into a power outlet.

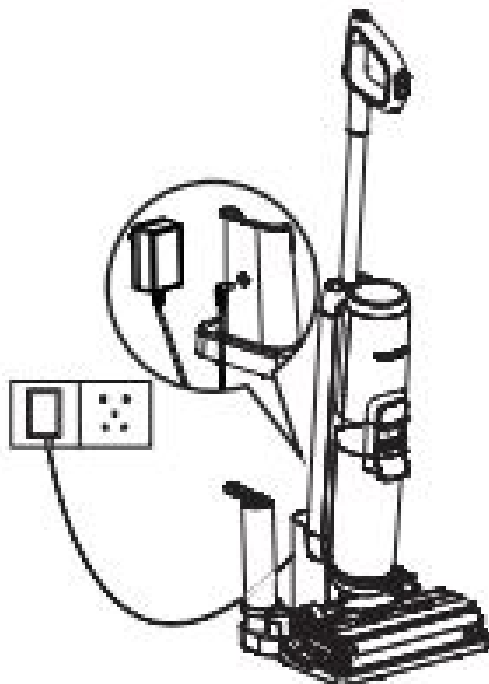

1. To charge the appliance, connect the external charging cord to the charging base and plug it into the wall outlet.
2. To avoid tripping hazards, please place the appliance on the charging base near a wall during charging.

**Warning:**

- Only charge the appliance with the adaptor supplied by Tineco.
- During long periods of not being used, the appliance must be charged once every 3 months for optimal performance. It may take 4-5 hours for a full charge.
- Store indoors in a dry place. Do not expose the appliance to sunlight or freezing temperatures.  
Recommended temperature range: 39.2°F (4°C) ~ 104°F (40°C).

**Digital Display**

An updated display shows everything with interactive animation, giving you a brand new experience during and after cleaning.

**Note:** Keep sharp objects away from the digital display screen to avoid scratches and scrapes.

**Cleaning Mode Selection****Auto Mode**

- In AUTO mode, the iLoop™ sensor automatically detects how dirty the floor is and applies the appropriate amount of detergent and suction power.
- A red dirt monitoring loop indicates more dirt is detected, and a blue loop indicates less dirt is detected. This mode automatically provides the best cleaning solution.

**MAX Mode**

- In AUTO mode, press the button to enter MAX mode.
- In Max mode, the appliance will apply max suction power and will spray water/solution for deeper cleaning

**SUCTION Mode**

- In MAX mode, press the button to enter SUCTION mode.
- In SUCTION mode, the appliance will only absorb water and do not spray. We recommend using this mode on the wet surface.

**Runtime**

- In AUTO/SUCTION mode: ~35minutes
- In MAX mode: ~28minutes
- Estimated runtime data was obtained by a Tineco Laboratory.

**Charging Time**



- A full charge takes approximately 4-5 hours.
- Estimated data was obtained by a Tineco Laboratory using ambient temperatures between 39.2°F (4°C) to 104°F (40°C).

## App

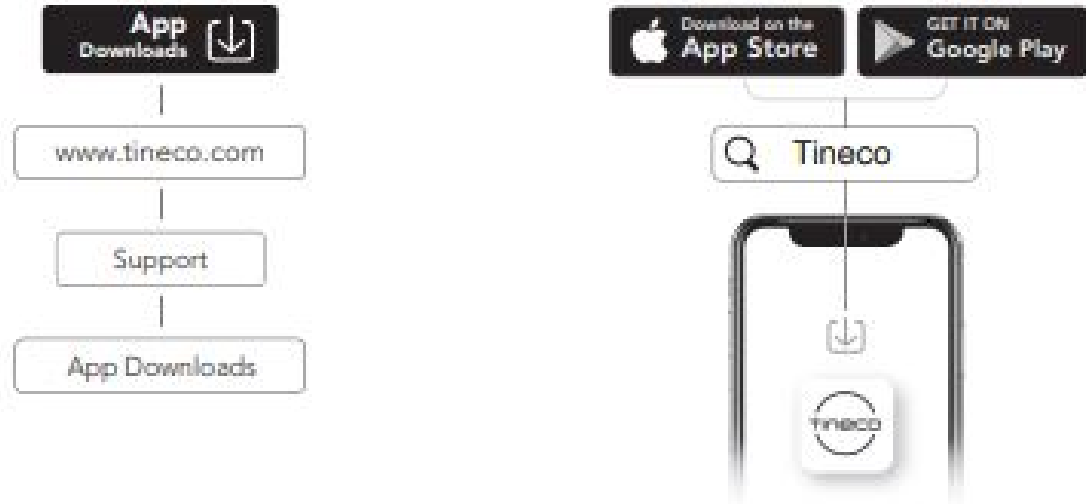

All the functions can be performed using the Tineco app. Download the Tineco app from the App Store, Google Play and Tineco Official Site.

**Note:** The default setting for voice prompt is English, you can set other languages via App.

**Voice Prompt** (Contents may vary, please in kind prevail.)

Status	Reminder
Voice prompts on	Voice prompts on
Voice prompts disabled	Voice prompts disabled
Auto mode by default	Auto mode

Switch to Suction mode	Suction mode
Switch to Max mode	Max mode
Cleaning with water only	Cleaning with water only
Cleaning with cleaning solution by default	Cleaning with cleaning solution
Battery level: 10~20%	Low battery
Battery level: 0~10%	Low battery, please charge
Clean Water Tank is empty	Clean Water Tank empty, please refill water and cleaning solution
Need self cleaning	Please begin self-cleaning cycle
Appliance not on the charging base	Please place appliance on charging base
Dirty Water Tank is full	Dirty Water Tank full, please empty
Dirty Water Tank not installed	Please install the Dirty Water Tank
Brush roller is tangled	Please clean the brush roller.

Brush roller not installed	Please install the brush roller correctly
Power is off	Power off
Start charging	Charging has commenced
Begin self-cleaning cycle.	Auto-detecting whether to run self-cleaning cycle, please begin self-cleaning cycle
Battery insufficient for self-cleaning	Low battery, start charging
Sufficient battery to start self cleaning	Start self cleaning
Cleaning brush roller	Cleaning brush roller
Cleaning debris channel	Cleaning debris channel
Auto detecting	Auto detecting
Deep cleaning	Deep cleaning
Self-cleaning stopped	Self-cleaning cycle stopped, please clean Dirty Water Tank
Self-cleaning complete	Self-cleaning cycle complete, please clean Dirty Water Tank

## Maintenance

### Note:

- For optimal performance and to prevent odors, always clean and dry DWT, filters, brush roller, brush roller cover completely after each use.
- Please make sure each part is installed correctly or the appliance may not work properly.
- After maintenance, place the appliance on the charging base vertically. Do not expose the appliance to direct sunlight, and store it indoors in a dry place.

### Main Body

To reduce the risk of injury, switch off before performing maintenance.

Use a cloth to clean the surface with a neutral detergent. The cloth should be dry to prevent water from entering the appliance.

When LED loop illuminates red, remove Dirty Water Tank, clean the dirt sensor with a damp cloth or the cleaning tool.

### Dirty Water Tank

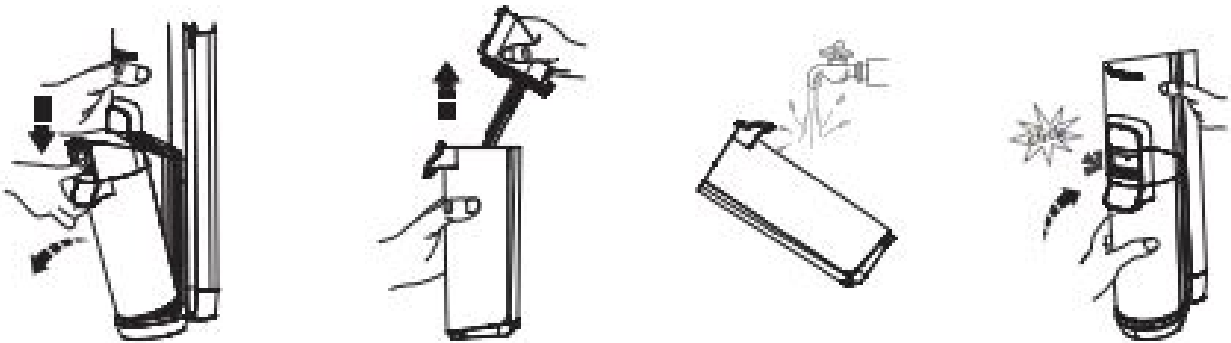

- When dirty water reaches the Max line, the appliance will stop working and show a reminder on the display and play a voice prompt.
- Pull up the tank lid to empty the DWT. Use the cleaning tool to remove remaining debris. Rinse the inside of the DWT and place back into the appliance.

### Dirty Water Tank Lid



If the Dirty Water Tank lid and the filter inside have been blocked, remove the tank lid and the filter, rinse both parts with water.

### Dry Filter



Grasp recessed area on each side of the dry filter and pull upward. Rinse under running water and must be completely dry before recombining with the lid of the DWT.

\* A spare dry filter is provided with your appliance for convenient replacement.

### Brush Roller Self-cleaning

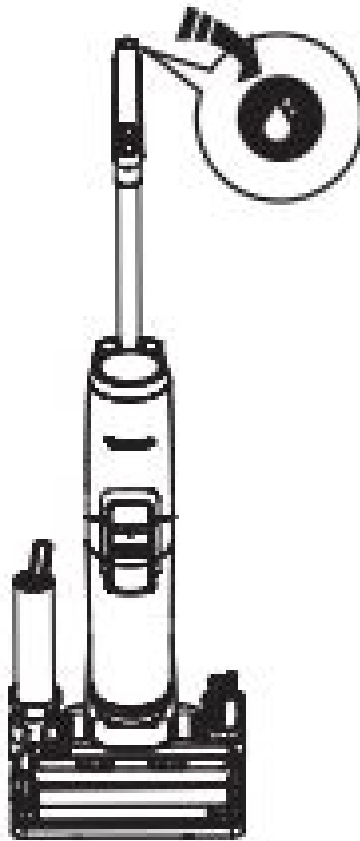

1. Place the appliance on the charging base after use, the sensor will auto-detect the level of dirt.
2. When you hear the voice prompt “please begin selfcleaning cycle,” press the self-cleaning button and begin the process.
3. Once complete, you will hear the voice prompt “selfcleaning completed, please clean the Dirty Water Tank.” At this point, the appliance will begin charging.

**Note:**

- Ensure the charging base is plugged in and the battery level is >10%.
- Before self-cleaning cycle, please clean the DWT and ensure the water level in the CWT exceeds 40%.

**Brush Roller Cover**

1. Squeeze latches on the cover and pull upward to remove.
2. Rinse with water.
3. When replacing, always latch the brush cover into place to avoid leakage.

**Brush Roller**

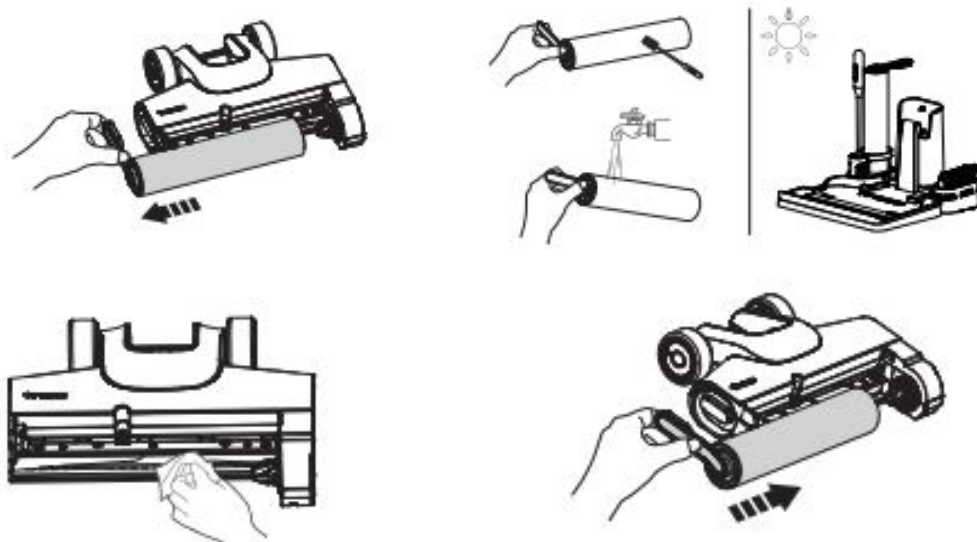

1. Remove the brush roller by grabbing the brush roller tab and pulling out.
2. Remove hair and debris from the brush roller chamber and the opening with a tissue or a damp cloth.
3. Using the cleaning tool, remove the hair and debris wrapped around the roller and rinse with water. Replace the brush roller back into the accessory holder, and allow it to dry completely before reinstalling.
4. Replace the brush roller by inserting the brush roller end into the right side of the holder, then attach the roller tab to the magnetic buckle on the left side to lock into place.

**Note:** A spare brush roller is provided with your appliance for convenient replacement.

## Specifications

Product	FLOOR ONE S5 PRO SERIES
AC Input	100~240V
Voltage	21.6V 4000mAh Lion
Rated Power	220W
Running Time	AUTO/SUCTION: ~35 mins MAX: ~28 mins
Charging Time	4-5 hrs
Water Flow Rate	30~100ml/min
CWT Capacity	~0.8L
DWT Capacity	~0.7L
Waterproof	IPX4

## Troubleshooting

Problem	Possible cause	Solution
---------	----------------	----------

The appliance does not turn on	Auto protection for overheating	Restart after cooling down
Weak suction	The dry filter is not installed, or the dry filter is dirty	Install the dry filter or clean and allow it to dry completely
Brush roller tangled in animation Voice prompt: 1. Please clean the brush roller 2. Please install the brush roller correctly	1. The brush roller is blocked 2. The brush roller is not installed	1. Remove blockages 2. Install brush roller correctly
WiFi indicator is off	WiFi is not connected	Follow the in-app guide to connect to WiFi
CWT empty in animation Voice prompt: Clean Water Tank empty, please refill water and cleaning solution	CWT is empty	Refill CWT
DWT full in animation Voice prompt: Please clean Dirty Water Tank	The dirty water in DWT has reached the MAX line	Empty the dirty water and then reinstall the DWT
All lights off in operation	Battery overheat or malfunction	Cool the appliance down and restart
Battery indicator in red Voice prompt: Low battery, please charge	Low battery	Charge the appliance, or restart



<p>LED loop illuminates red Voice pro mpt:</p> <p>Please begin self-cleaning cycle</p>	<p>Dirt sensor malfunction or blocked</p>	<p>Remove blockages, clean the debris channel, or restart</p>
--	---	---

## Warranty

### 2-YEAR LIMITED WARRANTY

Your washer, in the case of domestic use, has a two year parts and labour warranty against product defects and failures when the product is used in accordance with the terms and conditions of this warranty statement.

This warranty is provided by Electrical Home-Aids Pty. Ltd. and commences from the original date of purchase and is not transferable; please retain your original proof of purchase for any warranty claims.

This warranty is valid only in the country where the washer is purchased.

The washer must be operated in accordance with these instructions and used only for domestic household cleaning. This washer is not fit to be used as an industrial washer, and is not designed for the collection of vitreous building material including particle board, construction products and similar products such as wood/ fibres, cement, fillers, fibre glass etc or excessive or frequent sand. The infrequent pick-up of these materials in these circumstances may be harmful to your washer and may void the warranty.

Accessories and consumables including filters, unless defective in manufacture are not subject to this warranty. In order to prolong the life of accessories and consumables, regular care and maintenance is recommended.

When properly used and cared for, your washer will render excellent service; refer to the instruction manual for further details, as misuse or failure to follow the instructions makes this warranty void.

In the event of service, claim or advice being needed, please contact: Electrical Home-Aids Pty. Ltd. Brandon Office Park, Building 3, First Floor 530-540 Springvale Road, Glen Waverley VIC, 3150, Australia 1800 562 653 (AUS) or 0800 562 653 (NZ) Monday-Friday 9am-5pm EST.

The decision to repair or replace the washer is at the sole discretion of Electrical Home-Aids Pty Ltd.

Electrical Home-Aids Pty Ltd decide to repair or replace the washer, it will do so at its own cost. Electrical Home-Aids Pty Ltd is unable to accept responsibility under this warranty for any repair work not carried out by an authorised Service Agent or from the use of non-genuine parts. If any part is no longer available or manufactured, Electrical Home-Aids Pty Ltd will replace it with a genuine functional replacement part.

This warranty does not apply to the cost of replacing any parts of the product due to normal wear and tear, alterations, improper installation, physical abuse, misuse or accidental damage. Any transportation costs involved in the repair of defective parts shall be borne by the claimant.

If proof of purchase cannot be provided at the time of a warranty claim or service, any work carried out on the washer is chargeable. The repair of the washer under this warranty does not extend the original period of warranty.

The benefits conferred by this warranty are in addition to all other rights and remedies in respect of the product as outlined under the Competition and Consumer Act and other State and Territory laws.

“Our goods come with guarantees that cannot be excluded under the Australian Consumer Law. You are entitled to a replacement or refund for a major failure and compensation for any other reasonably foreseeable loss or damage. You are also entitled to have the goods repaired or replaced if the goods fail to be of acceptable quality and the failure does not amount to a major failure.”

### Call our Customer Service:

AUS: 1800 815 270

NZ: 0800 282 288

Or email our Customer Service:

[customerservice@godfreys.com.au](mailto:customerservice@godfreys.com.au)

[customerservice@godfreys.co.nz](mailto:customerservice@godfreys.co.nz)

Visit Official Website:

[www.godfreys.com.au](http://www.godfreys.com.au)

[www.godfreys.co.nz](http://www.godfreys.co.nz)

 <p>tineco FLOOR ONE S5 PRO SERIES Smart Cordless Vacuum &amp; Washer Instruction Manual</p>	<p><a href="#">Tineco 6470641 Floor One S5 Pro Series Smart Cordless Vacuum and Washer</a> [pdf] Instruction Manual 6470641, Floor One S5 Pro Series Smart Cordless Vacuum and Washer</p>
---	---

## References

- [↑ Official Site | Tineco](#)
- [📍 Godfreys NZ | New Zealand's Leading Vacuum & Cleaning Specialists](#)
- [📍 Godfreys | Australia's Vacuum and Cleaning Specialists](#)

## Related Posts



### [CELLAY VC1901LYC Wet and Dry Vacuum Floor Washer Instruction Manual](#)

VC1901LYC Wet and Dry Vacuum Floor Washer



### [ILIFE-V55 Pro Robot Vacuum Cleaner Instruction Manual](#)

ILIFE-V55 Pro Robot Vacuum Cleaner



### [Tineco Floor One S5 Pro Series Smart Cordless Vacuum and Washer Instruction Manual](#)

Floor One S5 Pro Series Smart Cordless Vacuum and Washer Instruction Manual Important Safety Instructions SAVE THESE INSTRUCTIONS...



### [iHunt PRO Robot Vacuum Laser User Guide](#)

iHunt PRO Robot Vacuum Laser Quick Guide Download iHunt Home app from Play Store (Android) or App Store...